

# PICCOLA S2

## Electromagnetic pump

Operation and Maintenance Manual  
Translation of original instructions



Manual drawn up in accordance  
with Directive 2006/42/EC

C24231E WK 22/25

<b>1.</b>	<b>INTRODUCTION</b>	<b>3</b>
<b>2.</b>	<b>GENERAL DESCRIPTION</b>	<b>3</b>
<b>3.</b>	<b>SAFETY AND PRECAUTIONS FOR USE</b>	<b>4</b>
<b>4.</b>	<b>PRODUCT IDENTIFICATION</b>	<b>5</b>
<b>5.</b>	<b>TECHNICAL SPECIFICATIONS</b>	<b>6</b>
<b>6.</b>	<b>MACHINE COMPONENTS</b>	<b>7</b>
<b>7.</b>	<b>UNPACKING AND INSTALLATION</b>	<b>9</b>
7.1.	UNPACKING	9
7.2.	ASSEMBLY OF THE PUMP	9
7.3.	ELECTRICAL CONNECTIONS	9
7.4.	HYDRAULIC CONNECTIONS	9
<b>8.</b>	<b>INSTRUCTIONS FOR USE</b>	<b>10</b>
8.1.	PUMP START-UP	10
8.2.	FILLING THE TANK	10
8.3.	REMOVING AIR FROM THE PUMP	10
<b>9.</b>	<b>PROBLEMS AND SOLUTIONS</b>	<b>11</b>

<b>10.</b>	<b>MAINTENANCE PROCEDURE</b>	<b>11</b>
<b>11.</b>	<b>DISPOSAL</b>	<b>12</b>
<b>12.</b>	<b>ORDER INFORMATION</b>	<b>12</b>
12.1.	ELECTROMAGNETICS (PICCOLA S2 PUMP)	12
<b>13.</b>	<b>OVERALL DIMENSIONS</b>	<b>13</b>
<b>14.</b>	<b>HANDLING AND TRANSPORT</b>	<b>14</b>
<b>15.</b>	<b>PRECAUTIONS FOR USE</b>	<b>14</b>
<b>16.</b>	<b>PRECAUTIONS FOR USE</b>	<b>15</b>

# 1. INTRODUCTION

---

This Operation and Maintenance Manual refers to the **PICCOLA S2** lubrication PUMP.

The latest version of this manual is available from the Technical-Commercial Office or from our website: <http://www.dropsa.com>

This Operation and Maintenance Manual contains important information for the health and safety of personnel who intend to use this equipment.

Please read this manual carefully and keep it in a safe place so that it is always available to operators who wish to consult it.

# 2. GENERAL DESCRIPTION

---

The **PICCOLA S2** electromagnetic pump is a compact and reliable unit designed for use in centralised oil lubrication systems. It is particularly suitable for installations on machine tools, automatic machining centres and other industrial applications where precise and cyclical lubricant metering is required.

The electromagnetic drive allows a high level of precision in controlling the amount of lubricant supplied and guarantees a long service life even in harsh environments. Its modular design, use of corrosion-resistant materials and ease of installation make this pump particularly suitable for integration into small and medium-sized automated systems.





There are two system variants available:









- **System 01:** ideal for applications with pressures up to 12 bar;
- **System 33V:** enhanced version reaching a maximum pressure of 13.5 bar and compatible with modular or progressive valve distribution systems.

### 3. SAFETY AND PRECAUTIONS FOR USE

It is important to read this manual before performing any operation. It is always recommended that the safety regulations of the country in which the equipment is installed be observed and that specialised personnel be used in the various maintenance, use, installation, etc. operations required during the life of the equipment.

Safety instructions and symbols in accordance with ANSI Z535, ISO 3864 and ISO 7010 are used in this manual and are listed below:

SAFETY WARNINGS TABLE			
SIGNAL WORD	DAMAGE TO	DEFINITION	CONSEQUENCES
	People	Indicates a dangerous situation which, if not avoided, will certainly result in death or serious injury.	Death or serious injury, paralysing.
		Indicates a dangerous situation which, if not avoided, could result in death or serious injury.	Possibly death or serious injury.
		Indicates a dangerous situation which, if not avoided, could result in minor or moderate injury.	Possible slight to moderate injuries.
	Property	Indicates practices not related to personal injury. Suggestions or other information.	Damage to property not to persons.

SYMBOL TABLE					
DANGER		PROHIBITION		OBLIGATION	
	General danger		Generic prohibition		Generic obligation
	Laser beam hazard		No smoking or open flames		It is mandatory to read the instructions
	Electrical hazard		Access prohibited with watches or metallic objects		Hearing protection must be used
	Danger: hot surface		Do not touch		Eye protection must be worn
	Danger: pressurized vessel		Do not extinguish with water		It is mandatory to ensure the earth connection
	Danger: crushing of hands				It is mandatory to disconnect the power supply
	Danger: explosive area				Protective gloves must be worn

## 4. PRODUCT IDENTIFICATION

A nameplate on the front of the pump tank shows the product code, power supply voltages and basic specifications.

VERSION SYSTEM 33V

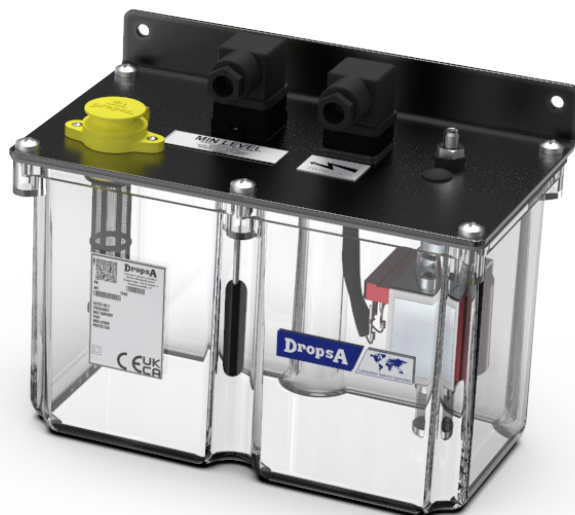
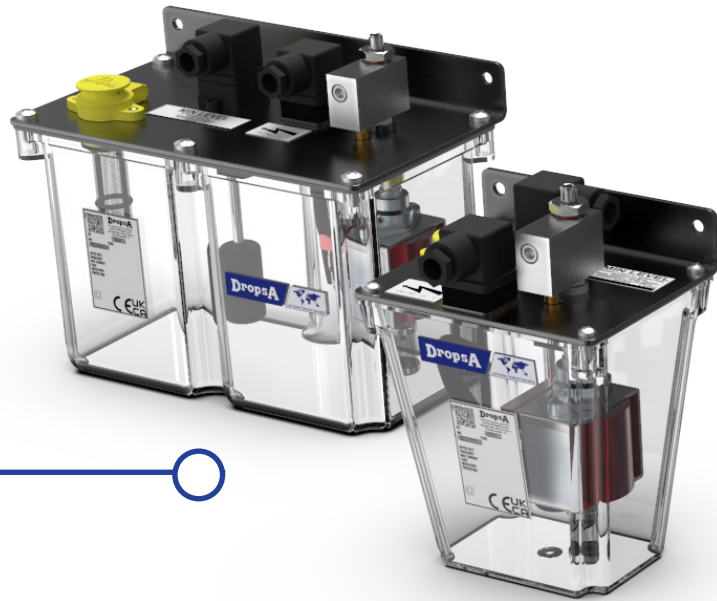

VERSION SYSTEM 01



### **WARNING**

It is forbidden to remove the pump nameplate.



## 5. TECHNICAL SPECIFICATIONS

GENERAL TECHNICAL CHARACTERISTICS		
Applicable product line	System 01	System 33V
Pump flow rate	(see table below)	(see table below)
Maximum pressure	12 bar (176.4 psi)	13.5 bar (198.45 psi)
Tank capacity	1 and 3 litres	1 and 3 litres
Maximum working time	2 min. (min. pause time is four times the working time)	2 min. (min. pause time is four times the working time)
Lubricant characteristics at operating temperature (mineral oil)	Mineral oils 15 - 220 CSt at 20° C	Mineral oils 32 - 100 CSt at 20° C
Operating temperature	- 5 °C to + 60 °C (+23 °F to +140 °F)	- 5 °C to +60 °C (+23 °F to +140°F)
Storage temperature	- 20 °C to + 60 °C (-4 °F to +140 °F)	- 20 °C to +60 °C (-4 °F to +140 °F)
Operating humidity	90% max	90% max
Electric IP rating	IP44	IP44
Noise level	<70 dB (A)	<70 dB (A)
Power supply voltages	Single-phase 24 - 120 - 230 V AC 50 Hz	Single-phase 24 - 120 - 230 V AC 50 Hz
Power consumption	90 W	90 W
Insulation	Class 1	Class 1
TECHNICAL CHARACTERISTICS OF TIMER (OPTIONAL)		
Working time	0 to 99 seconds	0 to 99 seconds
Pause time	0 seconds to 99 minutes	0 seconds to 99 minutes
Absorbed current	1A max	1A max
Operating temperature	From -10 °C to +50 °C (14°F to +122 °F)	From -10 °C to +50 °C (14°F to +122 °F)
Degree of protection	IP65 assembled	IP65 assembled
Connection	DIN 43650 A/ISO 4400	DIN 43650 A/ISO 4400
Operating voltage	24-240 V AC 50/60 Hz	24-240 V AC 50/60 Hz
Indicators	Electronic Display + LED	Electronic Display + LED

### NOTICE

The flow rates of the **PICCOLA S2** pump as shown in the table, were performed at a constant fluid temperature of 20°C.

FLOW RATE			
OIL DENSITY	0 BAR PRESS.	5 BAR PRESS.	8 BAR PRESS.
32 cSt (149.9 SUS)	280 cm <sup>3</sup> / min (17.1 cu.in)	180 cm <sup>3</sup> / min (11 cu.in)	130 cm <sup>3</sup> / min (7.9 cu.in)
100 cSt (462.6 SUS)	170 cm <sup>3</sup> / min (10.4 cu.in)	120 cm <sup>3</sup> / min (7.3 cu.in)	90 cm <sup>3</sup> / min (5.5 cu.in)
220 cSt (1018 SUS)	80 cm <sup>3</sup> / min (4.9 cu.in)	60 cm <sup>3</sup> / min (3.4 cu.in)	50 cm <sup>3</sup> / min (2.7 cu.in)



### CAUTION

Do not power the machine using voltage or pressure values other than the ones indicated on the nameplate.

## 6. MACHINE COMPONENTS

The main part of the pump is the support plate onto which all the equipment required for operation is fixed.

- The tank is made of transparent plastic which is compatible with commercially available lubricants.
- The **PICCOLA S2** pump is able to reach 12 bar (Line 01), 13.5 bar (33V system) with minimal power consumption.
- The SAMBA sensor indicates when the minimum level is reached via an electrical contact. The contact can be set as NC or NO (see drawing on page 7), standard NC.
- The timer (optional) is suitable for pause/run control of the pump in automatic cycle.

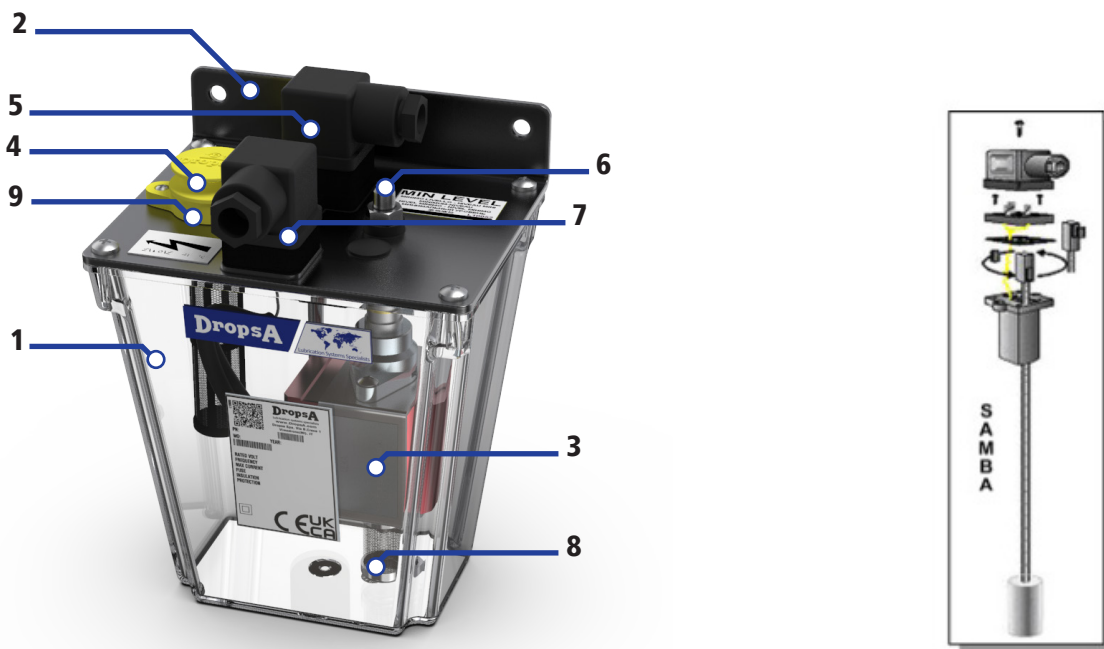

ITEM	CODE	DESCRIPTION
1	6770080	Tank 1000 cc
	6770033	Tank 3000 cc
2	3050270	Support bracket
3	3099260	Electric pump ulka ceme E5 - 24 V AC
	3099261	Electric pump ulka ceme E5 - 120 V AC
	3099262	Electric pump ulka ceme E5 - 230 V AC
4	6770070	Snaplock oil filler cap
5	1655583	SAMBA level switch without NC connection
6	3084295	Outlet connection G 1/8" x M 8x1
7	0039976	MPM connector 183-9-N DIN 43650
8	3130548	Filter
9	3130101	Oil filler filter

## 5.1 PROGRAMMING THE TIMER

Setting the working time:

- Press the ON button for 3 seconds.
- 'Sec' flashes on the display.
- The previous ON time setting is displayed with activation of the corresponding RED LED.
- Press the ON button to the left to increase the time or press the OFF button to the right to decrease the time.
- Press the TEST/ENTER button to confirm the schedule entered.

Setting the pause time:

- Press the OFF button for 3 seconds.
- 'Min' flashes on the display.
- The previous OFF time setting is displayed with activation of the corresponding GREEN LED.
- Press the ON button to the left to increase the time or press the OFF button to the right to decrease the time.
- Press the TEST/ENTER button to confirm the schedule entered.

Connection with 33V valves and maximum pipe lengths  
(4 valves - 0.03 to 0.50)

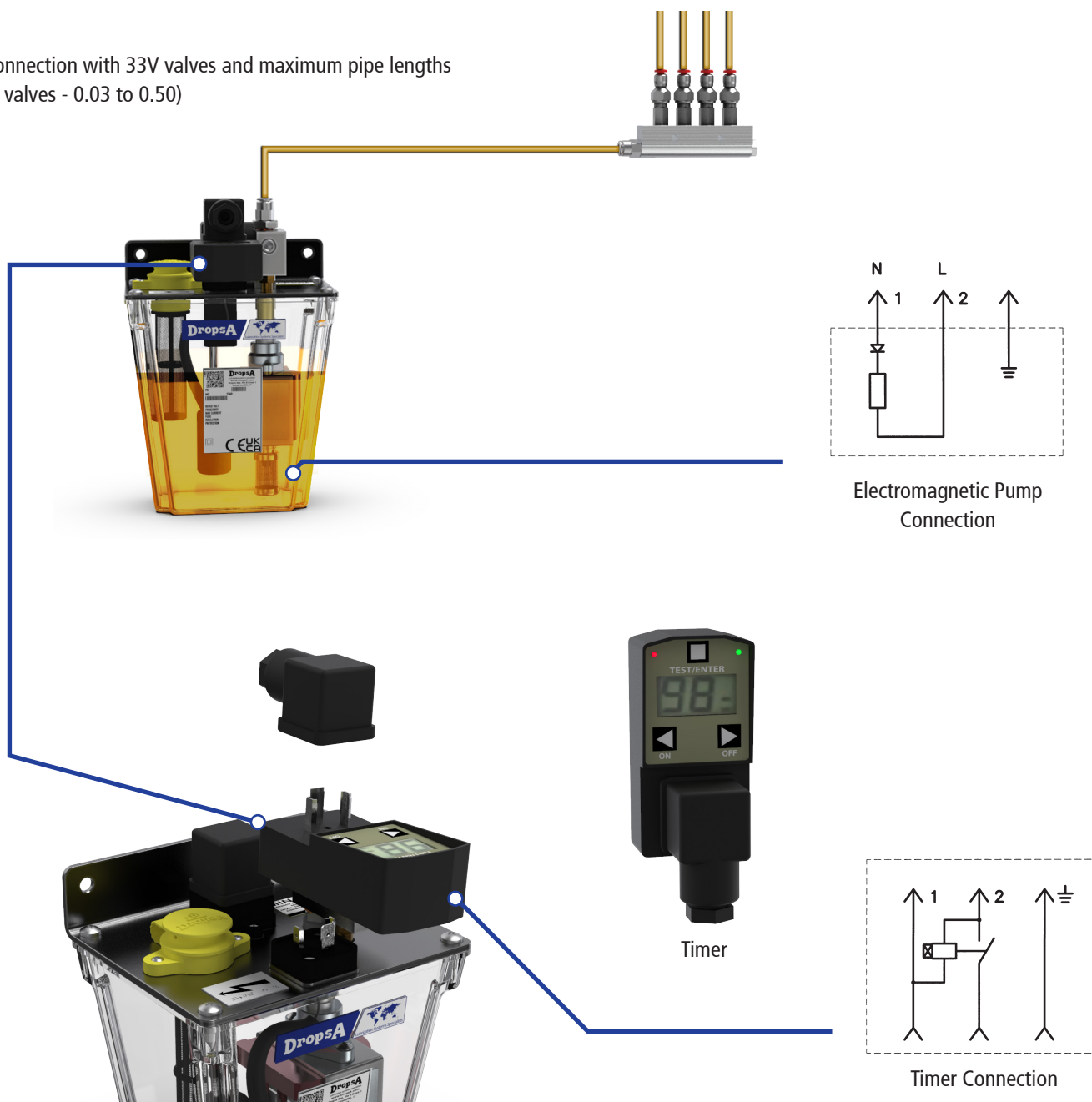



## 7. UNPACKING AND INSTALLATION

### 7.1. UNPACKING

Once you have identified a suitable place for installation, open the packaging and remove the pump. Check that it has not been damaged during transport and storage.

The packaging material does not require special disposal precautions, as it is not dangerous or polluting in any way.

For correct disposal, please refer to local regulations.



### CAUTION

The unit may only be opened and repaired by trained personnel.

### 7.2. ASSEMBLY OF THE PUMP

Ensure adequate space for the installation, leaving a minimum perimeter gap of 100 mm and install the pump at a height that is easily and comfortably accessible by the user to avoid abnormal postures or the possibility of impacts.

Do not install the pump in particularly aggressive or explosive/flammable environments or on parts which are subject to vibration.

Only use the mounting bracket equipped with 2 holes for Ø6 mm screws.

### 7.3. ELECTRICAL CONNECTIONS

Before any operation, check the type of power supply required for the machine. This can be seen on the nameplate located near the connector and on the tank plate.

The panel must be interconnected to the emergency switches of the serviced machine.

In order to prevent electrocution hazards due to direct or indirect contact with live parts, the power supply line must be adequately protected by an appropriate differential circuit breaker switch with a tripping threshold of 0.03 amperes and maximum tripping time of 1 millisecond.

**The breaking capacity of the circuit breaker must be = 10 kV and the rated current  $I_n$  = 6 A.**

### 7.4. HYDRAULIC CONNECTIONS

The hydraulic connection to be made to connect the pump to the system is located on the support plate. The thread present is standard M 8x1 with a double cone seat for a Ø4 mm pipe.

### NOTICE

After all connections have been completed, ensure that pipes and cables are protected from impact and properly secured.

## 8. INSTRUCTIONS FOR USE

### 8.1. PUMP START-UP

Before using the pump, it is necessary to carry out some preliminary checks:

- Check the integrity of the pump.
- Check that the hydraulic and electrical connections are correct.
- Fill the tank with a suitable lubricant.
- Start the pump and check that it is operating correctly.
- Check that the pump is at operating temperature and that there are no air bubbles inside the pipes.

Unless otherwise specified by the Customer, the minimum level status (fig. 1) is provided with closed contact if there is no oil present. If a normally open contact is required, please contact the Dropsa Technical Office.

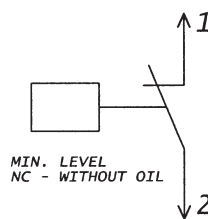
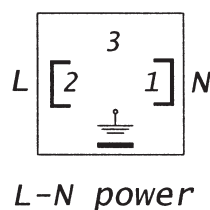

### 8.2. FILLING THE TANK

Only use suitable lubricants and only fill via the oil filler cap.  
Never introduce lubricant directly into the tank.

### 8.3. REMOVING AIR FROM THE PUMP

The presence of air in the circuit does not create problems for pump operation, but it is advisable to eliminate it from the system. To remove air, run the pump until the lubricant comes out without any traces of air (do not run the pump without lubricant). Carefully read the warnings regarding the risks involved in using a pump for lubrication. The operator must be familiar with the operation and must clearly understand what the dangers are having read and understood the Operation Manual.

## 9. PROBLEMS AND SOLUTIONS

A diagnostic table is provided below, highlighting the main anomalies, probable causes and possible solutions. If any issues and/or problems cannot be resolved, contact the Dropsa Technical Office rather than proceeding with troubleshooting by dismantling parts of the machine.

PUMP DIAGNOSTIC TABLE		
PROBLEM/ISSUE	PROBABLE CAUSES	INTERVENTIONS
<ul style="list-style-type: none"> <li>The pump is working but does not deliver oil or does not deliver the exact prescribed amount</li> <li>The pump does not deliver oil at the prescribed pressure</li> </ul>	<ul style="list-style-type: none"> <li>It sucks in air as the reservoir is empty</li> <li>The fittings are loose</li> <li>Clogged intake filter</li> <li>Pump worn</li> </ul>	<ul style="list-style-type: none"> <li>Restore the level in the reservoir and bleed air from the system</li> <li>Carefully close all fittings, ensuring that there are no leaks</li> <li>Clean the filter or replace it</li> <li>Replace the pump</li> </ul>
<b>The pump does not release</b>	<b>Clogged or plugged release valve</b>	<b>Replace the release valve</b>

## 10. MAINTENANCE PROCEDURE

The pump has been designed and built to require minimal maintenance.

To simplify maintenance, it is recommended that it be mounted in an easily accessible position.

Check pipe joints periodically for leaks. Always keep the pump clean in order to promptly detect any leaks.

As and when required, replace the oil filler filter, code 3130101 and the suction filter, code 3130071.

Always use lubricants with no impurities present.

Proceed with scheduled maintenance as follows:

VERIFICATION	WORKING CYCLES
Check correct lubrication	1,000
Clean the filling filter	4,000
Clean the reservoir at the bottom if there are any deposits present	6,000

The machine does not require special equipment for inspection and/or maintenance.

The use of suitable tools and PPE (gloves) is recommended in ref. to Italian Legislative Decree 81/08. They must be in good condition to avoid personal injury or damage machine parts.

### NOTICE

Make sure that the power and hydraulic supplies are disconnected before carrying out any maintenance work.

## 11. DISPOSAL

During machine maintenance, or in the event of its demolition, do not dispose of polluting parts in the environment. Refer to local regulations for the correct disposal procedure. When disposing of the machine, the identification nameplate and any other documents must be destroyed.

## 12. ORDER INFORMATION

### 12.1. ELECTROMAGNETICS (PICCOLA S2 PUMP)

SYSTEM 01			33V SYSTEM		
PUMP DESCRIPTION	CODE 1 L	CODE 3 L	PUMP DESCRIPTION	CODE 1 L	CODE 3 L
PICCOLA S2 PUMP 24 V AC	3600330	3600333	PICCOLA S2 PUMP 24 V AC	3600340	3600343
PICCOLA S2 PUMP 120 V AC	3600331	3600334	PICCOLA S2 PUMP 120 V AC	3600341	3600344
PICCOLA S2 PUMP 230 V AC	3600332	3600335	PICCOLA S2 PUMP 230 V AC	3600342	3600345

### ACCESSORIES

1524492

Pump timer kit 120-230 V AC

### SPARE PARTS

1524510

PICCOLA release valve S2 33V (up to 12 points)

## 13. OVERALL DIMENSIONS

To facilitate future maintenance, increase the spaces indicated by at least 100 mm (3.9 in.).

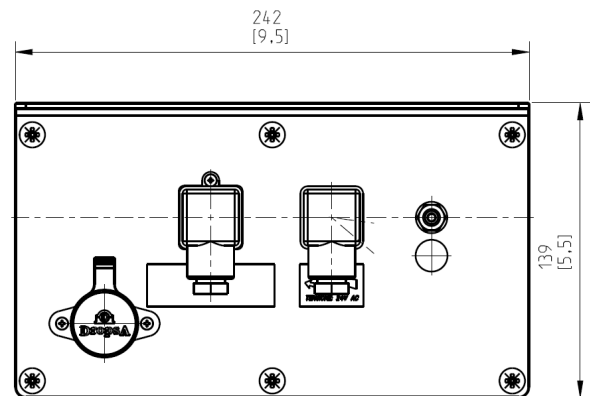
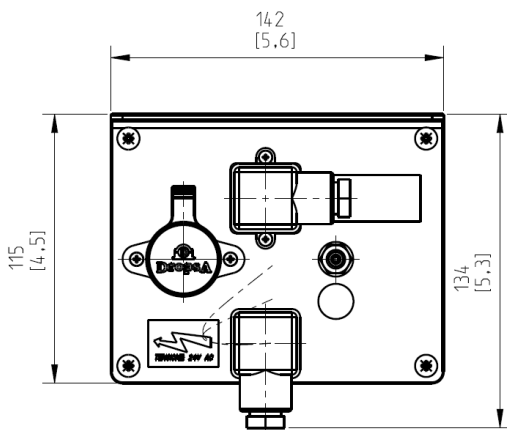
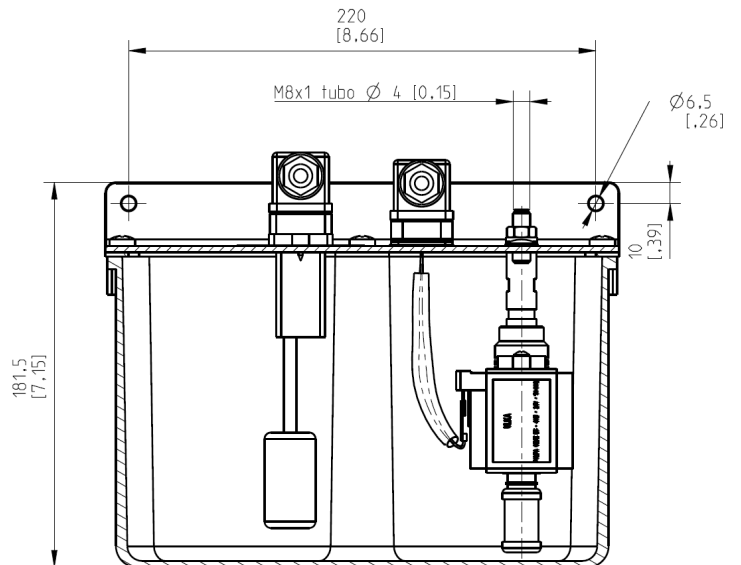
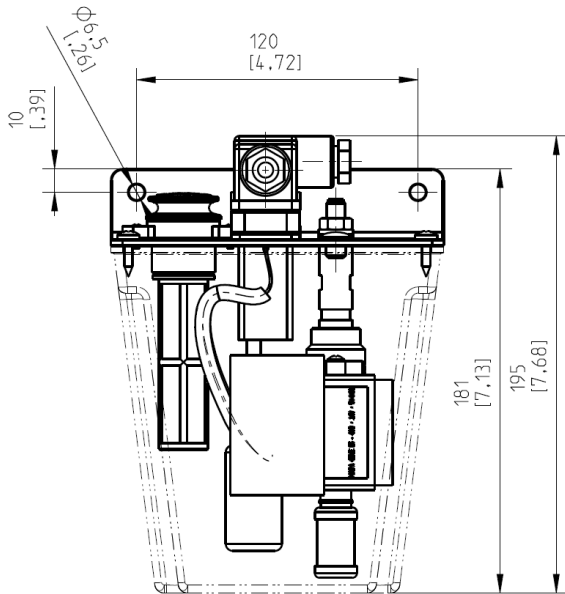

Piccola S2 Pump, 1 litre version - 1.5 Kg  
 Piccola S2 Pump, 3 litre version - 2.2 Kg

## 14. HANDLING AND TRANSPORT

Due to the pump's small size and weight, handling operations do not require the use of lifting equipment.

Before shipping, the pumps are carefully packed in a cardboard box.

When transporting and storing pumps, pay close attention to the direction indicated on the box.

Upon receipt, check the packaging for damage and store the pump in a dry place.

Lift the equipment in the direction indicated on the cardboard packaging.

The machine components can withstand temperatures ranging from -20 to +60 °C (-4°F to 140°F) during storage. However, to avoid damage, the machine must only be started up when it has reached a temperature of at least +5 °C (41°F).

## 15. PRECAUTIONS FOR USE

Carefully read the warnings regarding the risks involved in using a pump for lubrication.

The operator must be familiar with the operation and must clearly understand what the dangers are having read and understood the Operation Manual.

### Electrical current

No work should be carried out on the machine unless it has been disconnected from the power supply, ensuring that nobody can reconnect it during the work.

All installed equipment (electrical, electronic, tanks and base structures) must be connected to the grounding line.

### Flammability

The oil used in lubrication circuits is not a normally flammable fluid. However, it is essential to take all possible precautions to prevent it from coming into contact with very hot parts or open flames.

It is a good idea to locate fire extinguishers in the vicinity of the lubrication systems to allow rapid intervention in the event of fire.

### Pressure

Before any work is carried out, check that there is no residual pressure in any branch of the lubricating circuit, which could cause oil splashes when fittings or parts are removed.

### Noise and vibration

The **PICCOLA S2** pump does not emit excessive noise, remaining below 70 dB(A).

## ⚠ CAUTION



CAUTION: Warnings about the risks involved in using a lubricant pump should be read carefully.  
The user must be familiar with operation through the Operation and Maintenance Manual.

## 16. PRECAUTIONS FOR USE

The **PICCOLA S2** pump has no particular contraindications except for the following points:

- Contact with oil during refilling/maintenance.
- The operator must be equipped with appropriate PPE (Italian Legislative Decree 81/08).
- Use of unsuitable lubricant.

### FLUIDS THAT ARE NOT PERMITTED

FLUID	DANGER
Lubricants with abrasive additives	High consumption of contaminated parts
Lubricant with silicone additives	Seizing of the pump
Petrol, solvents, flammable liquids	Fire, explosion, damage to the gaskets
Corrosive products	Pump corrosion, personal injury
Water	Pump oxidation
Food substances	Contamination

## Copyright

©2025 DropsA S.p.A. Via Benedetto Croce,1  
20055 Vimodrone (MI)

This document is protected by copyright.

All rights reserved, including translation.

All rights reserved in the case of patent granting or utility model registration.

No part of this document may be reproduced in any form (e.g. printed matter, copy, microfilm or any other method) or processed, duplicated or distributed in data processing systems.

Failure to comply will lead to liability for damage.

Reprints, including of excerpts, are only permitted with the approval of DropsA S.p.A.

We reserve the right to make technical changes to the machine at any time in order to improve safety, reliability, functionality and design.

All descriptions and information in this product catalogue apply to the current state at the time of creation.

We reserve the right to change the content of this document without prior notice.

We would like to point out that the software and hardware designations used in this document and the trade names of individual companies are subject to general protection under trademark or patent law.

The text and design representation may not necessarily conform to the product delivered.

Technical drawings cannot necessarily be drawn to scale.