



## CHARACTERISTICS

- PUMPING OUTLET CONNECTION: 1/4" BSP
- ADJUSTABLE FLOW ON EACH PUMP ELEMENT
- ABILITY TO SPLIT LUBE AND PROCESS LUBRICANT INLETS AT ANY PUMP ELEMENT POINT (1/3 – 2/2 – 3/1 CONFIGURATION)
- OPTION OF COMBINING OUTPUTS WITH BRIDGE ELEMENT

## LINE PUMP ADVANCED DESIGN AND SOLUTIONS

The LINE piston pump is an efficient and economic solution used in centralized systems that satisfies different flow rates and pressures in continuous oil lubrication systems. The LINE pump is assembled using standard modular components.

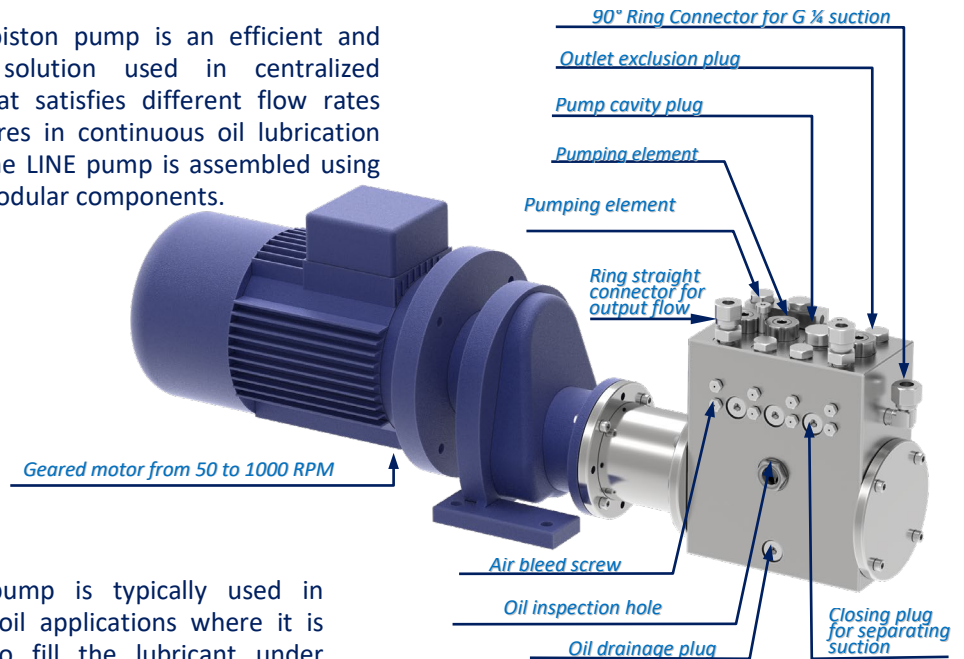

The Line pump is typically used in continuous oil applications where it is necessary to fill the lubricant under constant pressure and flow (Eg. bearings, hubs, pins, joints, etc ...).

Operated by a crankshaft and cam mechanism, the pump, combined with the appropriate pressing disc, ensures lubricant suction without air pockets.

## APPLICATIONS

- PETROCHEMICAL REFINERIES
- CYLINDER AND ROD / PISTON LUBRICATION
- GAS HANDLING
- REFRIGERATION CELLS
- COMPRESSOR LUBRICATION
- RUBBER / PLASTICS

The **LINE pump** is a piston pump with spring return driven by an **eccentric drive shaft**. The flow rate of the pump is easily adjustable.

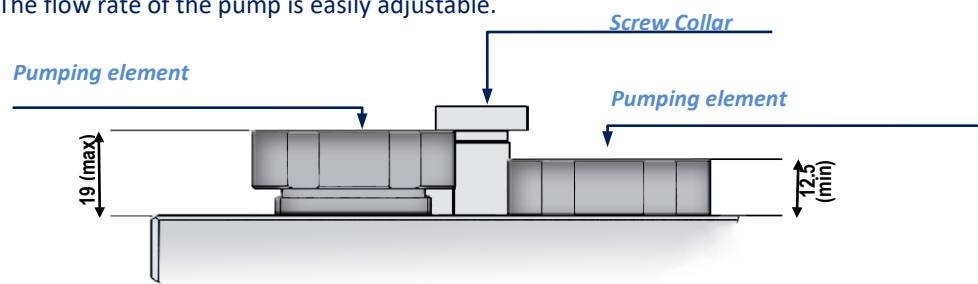

Attention! Do not exceed indicated dimension (19mm)

THE LINE PUMPS ARE CAPABLE OF PROVIDING EXACT FLOW AT HIGH PRESSURES FOR LUBRICATION HYDROSTATIC LUBRICATION. THEY ARE ESPECIALLY SUITED FOR USE WITH CENTRALIZED LUBRICATION SYSTEMS.



All working components within the pump are protected from contamination, water, impurities and are continuously self-lubricated by the process lubricant. It is therefore not necessary to change oil in the pump casing.

A robust construction renders the LINE pump a highly reliable device. The piston has been designed with sufficient stroke-volume to avoid any risk of aerating the oil and scavenging problems.



## DIMENSIONS (NOT TO SCALE)

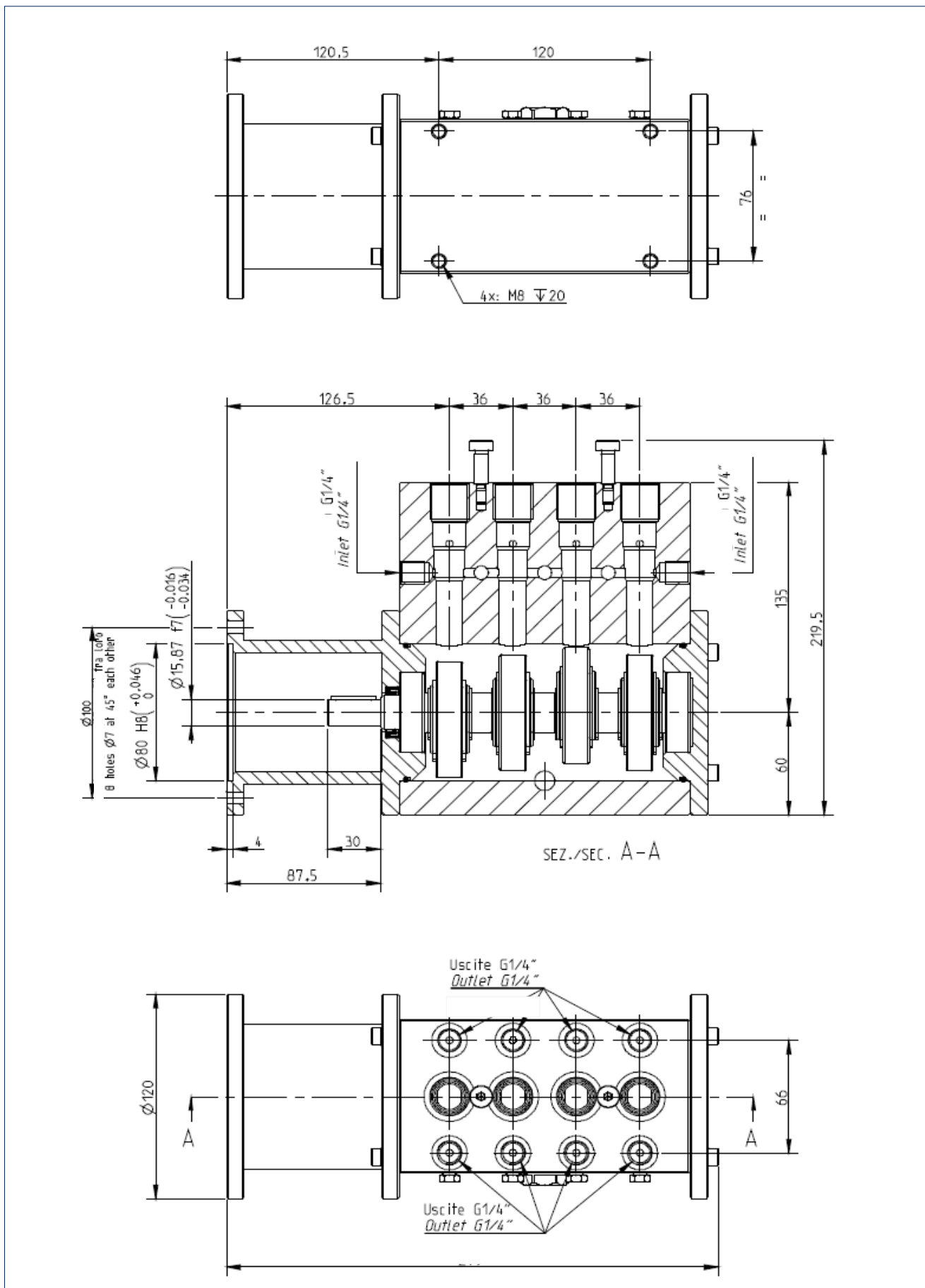



## TECHNICAL INFORMATION

TECHNICAL SPECIFICATIONS		
Pumping system		Eccentric driven piston pump with spring return
Pumping outlet connection		G 1/4 UNI – ISO 228/1
Reservoir inlet connection		G 1/4 UNI – ISO 228/1
RPM		50 - 1000
Rotation direction		Bidirectional
Conservation Temperature		+5°C - +40°C
Pumping delivery	Ø6	Stroke tot. 8mm used 6.5mm 0.177cm <sup>3</sup> /rev (adjustable)
Outlet pressure	Ø6	550bar (constant) 690bar (intermittent)
Inlet pressure		0.1bar - 44bar
Lubricant viscosity		10.5cSt - 462cSt
Storage temperature		-30°C - +80°C
Max. relative humidity without operating condensation		90%
Sound pressure level		< 70 db (A)
Net weight		9Kg (without geared motor)

As standard the pumps should be ordered factory set to customer requirements. If necessary, the pumping elements can be adjusted: rotating the pump clockwise increases the flow and rotating anticlockwise decreases the flow. The graph on the next page below shows the range of adjustment that can be achieved on the pump.

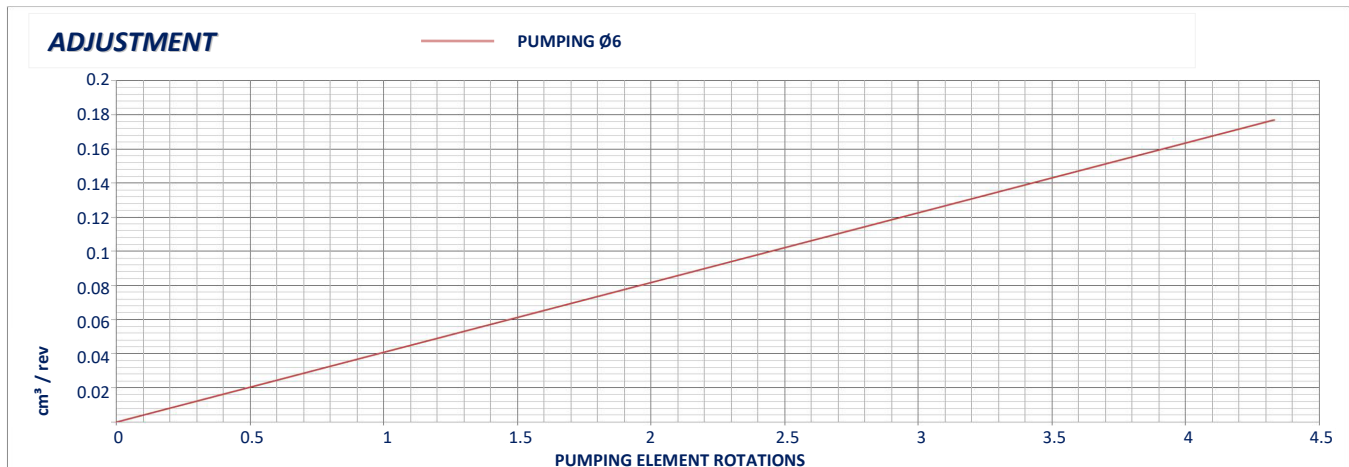

GRAPHIC N. 1

The choice of pumping elements is based on the output required and the RPM of the geared motor. Refer to the following graph for each pump output.

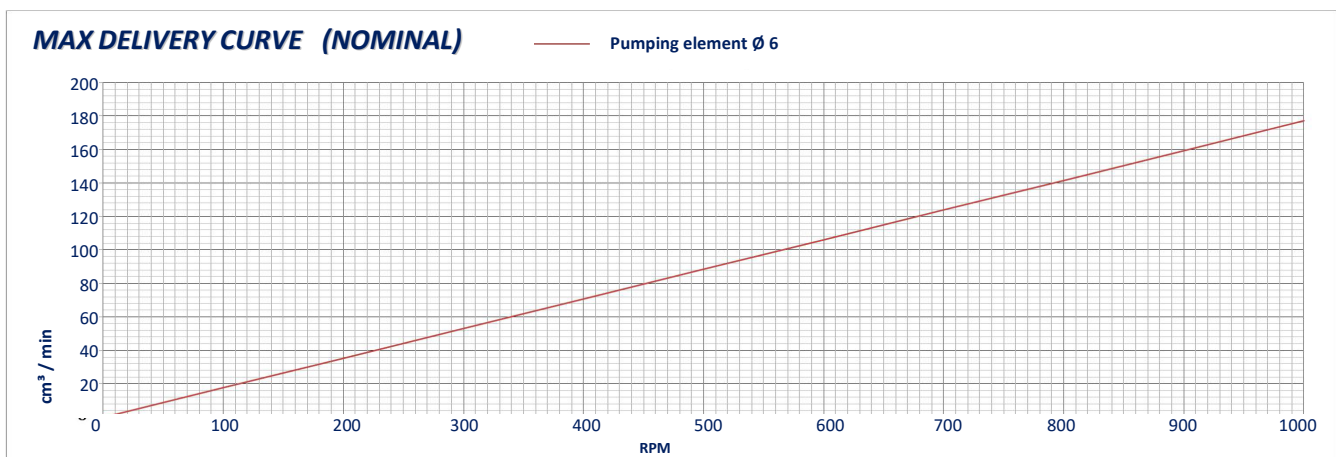

GRAPHIC N. 2



## ORDER INFORMATION

The LINE pump configurations allow the customer to use it in many applications and conditions.

*Description of variables:*

**Positions A-B-C-D (see image 2)**

This refers to the position of where the pumps are installed in the unit. You can use all 4 pumps or plug unused pump cavities. The pumps sizes available are Ø6 or Ø10 and are both adjustable).

### Position E

With a purpose-built pin inserted at various positions the pump inlet can be divided. For example, applying the pin at position E2 will separate the inlet to pump elements A-B from inlet to pump elements C-D allowing to different lubricants to be used.

### Position I-L

If the bridging unions are not used, the output threads must be plugged off with the appropriate plugs. The positioning of the plugs must be done correctly considering the number of pumps used. For example: if using only 1 pump element in Position A, with B-C-D plugged, output side I1 or I3 can be selected by plugging the unused outlet.

### Position F-G-H

The outputs F1-F2-G1-G2-H1-H2 can be joined with a bridging union allowing the combination of flow into a single outlet.

### Position M

The pump can be ordered with or without a geared motor. Please refer to the table below. If a special geared motor is required and it is not listed, please contact the Dropsa sales office to check availability.

### PART NUMBERING

3099180

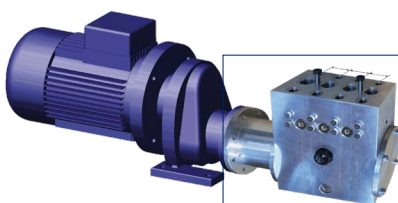

A		G	
0	PLUG		W/OUT BRIDGE
1	PUMPING Ø6	1	BRIDGE POS. 1
		2	BRIDGE POS. 2

B		H	
0	PLUG		W/OUT BRIDGE
1	PUMPING Ø6	1	BRIDGE POS. 1
		2	BRIDGE POS. 2

C		I	
0	PLUG	A	W/OUT PLUGS
1	PUMPING Ø6	B	PLUG IN POS. 1
		C	PLUG IN POS. 2
		D	PLUG IN POS. 3
		E	PLUG IN POS. 4
		F	PLUG IN POS. 1+2
		G	PLUG IN POS. 3+4
		H	PLUG IN POS. 1+4
		I	PLUG IN POS. 2+3
		L	PLUG IN POS. 1+2+3
		M	PLUG IN POS. 1+2+4
		N	PLUG IN POS. 2+3+4
		O	PLUG IN POS. 1+3+4
		P	PLUG IN POS. 1+2+3+4

D		L	
0	PLUG	A	W/OUT PLUGS
1	PUMPING Ø6	B	PLUG IN POS. 1
		C	PLUG IN POS. 2
		D	PLUG IN POS. 3
		E	PLUG IN POS. 4
		F	PLUG IN POS. 1+2
		G	PLUG IN POS. 3+4
		H	PLUG IN POS. 1+4
		I	PLUG IN POS. 2+3
		L	PLUG IN POS. 1+2+3
		M	PLUG IN POS. 1+2+4
		N	PLUG IN POS. 2+3+4
		O	PLUG IN POS. 1+3+4
		P	PLUG IN POS. 1+2+3+4

E		M	
0	W/OUT DIVISION	0	WITHOUT GEARED MOTOR
1	DIVISION A-BCD	1	681 RPM - 2.2kW (°) (°°)
2	DIVISION AB-CD	2	628 RPM - 1.5kW (°)
3	DIVISION ABC-D	3	1025 RPM - 2.2kW (°) (°°)
		4	1111 RPM - 1.5kW (°)
		5	N/A
		6	N/A
		7	N/A
		8	N/A
		9	N/A

F	
	W/OUT BRIDGE
1	BRIDGE POS. 1
2	BRIDGE POS. 2

### PICTURE N. 2

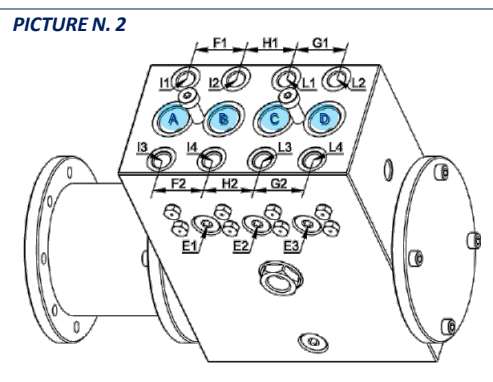

(°) 230/400V – 240/415V – 50Hz  
3Ph 280/480V – 60Hz – 3Ph

(°°) With Anti condensation  
240V – 50Hz – 1Ph

ACCESSORIES AND SPARE PARTS			
CODE	DESCRIPTION	CODE	DESCRIPTION
0299654	Pumping Ø6	0092243	Straight Ring Connector for tube Ø10
3234309	Pump cavity plug	0093485	90° Ring Connector for tube Ø12
0017144	Plug dividing the suction outlets	0622167	Plug for excluding outlet
0641321	Bridge Union for combining flow	3230149	Air bleed screw
0265037	Oil inspection hole	3301550	geared motor 681 RPM - 2.2kW (M1)
3234253	Oil drainage plug	3301553	geared motor 628 RPM - 1.5 kW (M2)
0010513	Neck screw	3301554	geared motor 1025 RPM - 2.2 kW (M3)
3200164	Pump /geared motor coupling	3301555	geared motor 1111 RPM - 1.5 kW (M4)