

## CHARACTERISTICS

- FOR OIL
- COMPATIBLE WITH:  
SYSTEM 01  
VALVE 33  
SYSTEM 26
- RESERVOIR CAPACITY:  
3-6 LITRES
- FLOW RATE:  
350-500 CM<sup>3</sup>/MIN
- BUILT-IN RELEASE  
VALVE
- BUILT-IN PRESSURE  
CONTROL VALVE

## GEAR MOTOR ELECTRICAL PUMP FOR AUTOMATIC LUBRICATION SYSTEMS

The **Dragon** pump series is specifically indicated, due to its compactness and versatility, for lubrication systems for presses, machine tools, reducers, guides, chains, etc.

Dragon is a gear motor pump, available in TWO VERSION: the first with a flow rate of 350 cm<sup>3</sup>/min, the second with a flow rate of 500 cm<sup>3</sup>/min, values considered at 1.500 rpm. This type of pump is tailored to customers' most diverse needs, thanks to a wide range of electric motors and reservoirs available.



### There are three different basic versions:

- For lubrication systems with injectors and circulations systems with operating pressures of <20 bar (290 PSI) – system 01.
- With a built-in release valve for lubeication systems equipped with “direct response” dosers, with operating pressures of <50 bar (735 PSI) – systems 33V.
- For progressive lubrication systems with circulation systems controlled by progressive dosers with operating pressures of <70 bar (1015 PSI) – system 26.

### Maximum pressure:

- Intermittent service is at 70 bars with a three-phase motor; 40 bars with a single-phase motor; maximum operation time of 5 minutes, pause with a ratio of 1:1.
- Continuous service is at 30 bars, with both a single-phase and three-phase motor.

Pressures are based on the type of lubricant, the voltage and timing of the motor.

The system must only be used with mineral lubricating oil, with a viscosity of 15 to 1000 cSt (at operating temperature); it is also possible to use NLGI 000 grease with a capacitive probe.

## APPLICATIONS

- PRESSES, MACHINES
- TOOLS
- REDUCERS
- GUIDES
- CHAINS

## TECHNICAL FEATURES

<b>Reservoir capacity</b>	3 litres in anti-oil transparent plastic 3 litres painted sheet metal with visual level 6 litres in anti-oil transparent plastic 6 litres painted sheet metal with visual level
<b>Compatible lubricants</b>	Mineral oils 15 - 1000 cSt Liquid grease NLGI 000
<b>Storage Temperature</b>	-20 ÷ +65 °C
<b>Power voltages</b>	Single-phase motor: 220 V, 50 Hz and 90w – on request: 110 50/60 Hz Special three-phase motor: 220/380 V, 240/415 V and 255/440 V Frequency 50 - 60 Hz and Power 90 W
<b>Absorption</b>	90 W
<b>Output signals</b>	Minimum level contact max 220 V 3A NA / NC
<b>Operating temperature</b>	+ 5 °C ÷ + 60 °C
<b>Operating humidity</b>	90% maximum relative humidity
<b>Electrical protection</b>	IP 55
<b>Continuous sound pressure level</b>	< 70 dB (A)

## DIMENSIONS

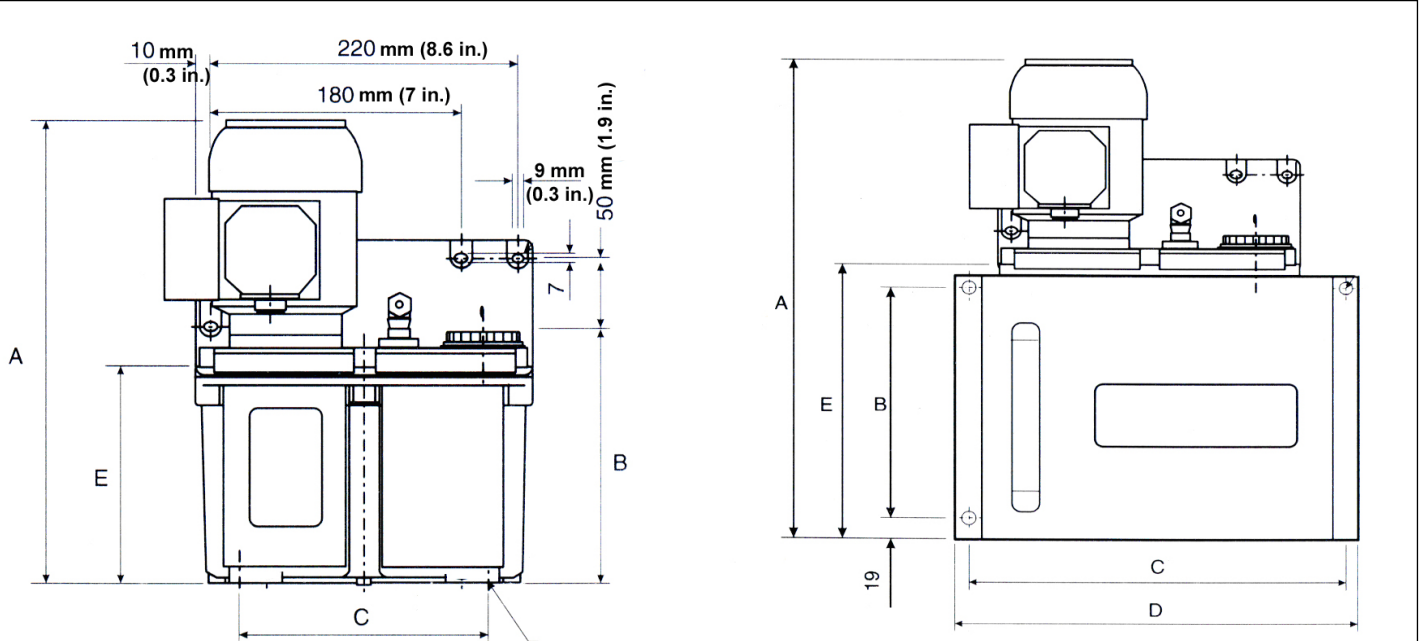

3-LITRE PLASTIC MATERIAL RESERVOIR		
	mm	inches
A	337.5	13.28
B	187	7.36
C	177.8x101.5	7.0x3.96
D	240	9.45
E	160.5	7.00

3-LITRE ALUMINIUM RESERVOIR		
	mm	inches
A	330	12.99
B	179	7.05
C	177.8x101.5	7.0x3.96
D	240	9.45
E	152.5	6.0

6-LITRE PLASTIC MATERIAL RESERVOIR		
	mm	inches
A	430.5	16.9
B	280	11
C	177.8x101.5	7.0x3.96
D	240	9.45
E	253.5	9.9

6-LITRE ALUMINIUM RESERVOIR		
	mm	inches
A	421	16.5
B	205	8.0
C	305	12.0
D	327	12.8
E	243.5	9.5

## ORDER INFORMATION

MOTOR	CAPACITY	RESERVOIR	SYSTEM 01	SYSTEM 33V	SYSTEM 26
THREE-PHASE MULTI-TENSION	350	3 transp.	<b>3901050</b>	<b>3902050</b>	<b>3903050</b>
		6 nylon	<b>3901052</b>	<b>3902052</b>	<b>3903052</b>
	500	3 transp.	<b>3901054</b>	<b>3902054</b>	<b>3903054</b>
		6 nylon	<b>3901056</b>	<b>3902056</b>	<b>3903056</b>
SINGLE-PHASE	350	3 transp.	<b>3901070</b>	<b>3902070</b>	<b>3903070</b>
		6 nylon	<b>3901072</b>	<b>3902072</b>	<b>3903072</b>
	500	3 transp.	<b>3901074</b>	<b>3902074</b>	<b>3903074</b>
		6 nylon	<b>3901076</b>	<b>3902076</b>	<b>3903076</b>

## ACCESSORIES

	DESCRIPTION	CODE
Two versions can be mounted according to the lubrication system: line 01 for uses with low pressures, 33v, line 26 for higher pressures.	Pressure gauge (0 25 bar)	<b>0020566</b>
	Pressure gauge (0 100 bar)	<b>0020564</b>
Two versions can be mounted according to the lubrication system: 10 ÷20 bar for uses with low pressures, 20 50 bar for higher pressures.	Pressure switch (low pressures)	<b>3291028</b>
	Pressure switch (high pressures)	<b>3291022</b>
It is also possible to provide a control panel as a pump accessory known as "VIP5" which enables various functioning parameters to be controlled: pressure switch (01.33v), cycle control (26), min. level, operating time setting and pause.	Control panel (single-phase 110 Vac)	<b>1639142</b>
	Control panel (single-phase 230 Vac)	<b>1639140</b>
	Control panel (three-phase)	<b>1639152</b>
It is necessary to predict when the pressure gauge and pressure switch are installed.	Adjustable terminale	<b>3085230</b>

Distributor Info: